

Certain formulas will be provided in the examination booklet. See your teacher for a copy of those formulas.

1. Look at the right triangle below.

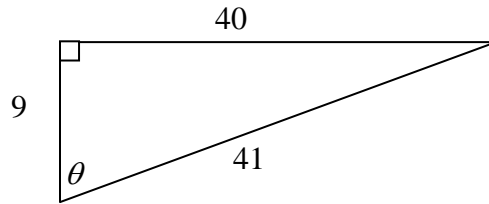

Note: Figure NOT drawn to scale

- a. Which of the following has a ratio of $\frac{40}{41}$?
- A** $\sin \theta$ **B** $\cos \theta$ **C** $\tan \theta$ **D** None of these
- b. Which of the following has a ratio of $\frac{40}{9}$?
- A** $\sin \theta$ **B** $\cos \theta$ **C** $\tan \theta$ **D** None of these

For problems 2 through 13, determine the value of x and/or y in each figure below.

Note: Figures NOT drawn to scale

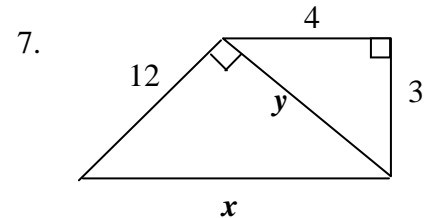
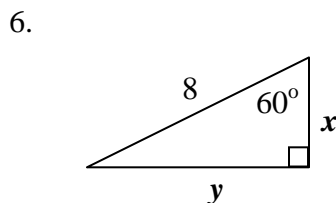
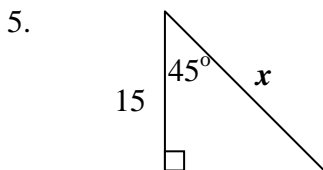
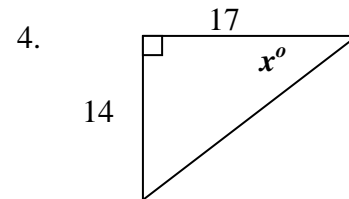
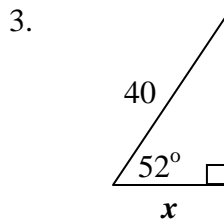
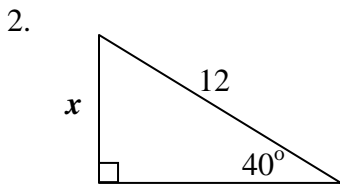

8.

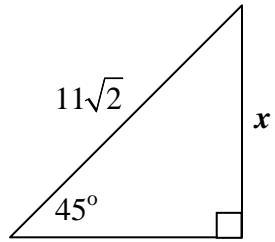

9.

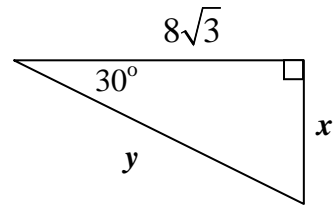

10.

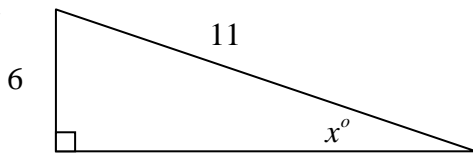

11.

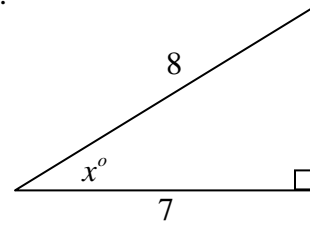

12.

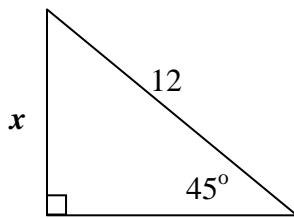

13.

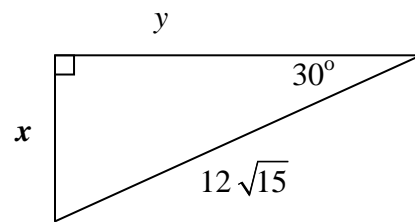

14. A jet plane begins a steady climb flies for 3 miles (15840 feet) at an angle of 12° with the ground. What was its change in altitude in feet?

15. A regular hexagon has an area of $96\sqrt{3}$ and an apothem of $4\sqrt{3}$. What is the length of each side of the hexagon?

- A** 2 **B** 4 **C** 8 **D** $8\sqrt{3}$

16. Determine the value of x in each figure below.

Note: Figures NOT drawn to scale

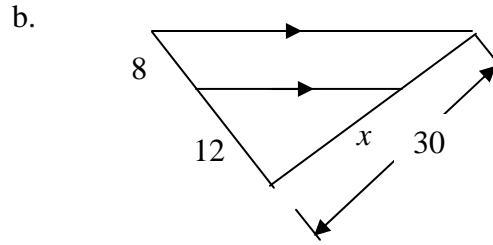
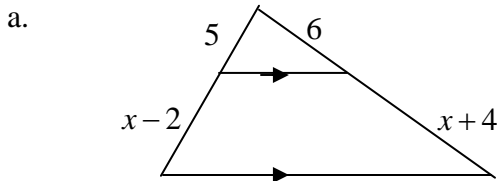

17. In the figure below, $\overline{AB} \parallel \overline{CD}$

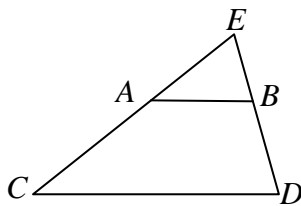

Note: Figure NOT drawn to scale

True or False?

- a. $\triangle EAB \sim \triangle ECD$
- b. $\frac{EA}{EC} = \frac{EB}{ED}$
- c. $\frac{EA}{AC} = \frac{EB}{BD}$
- d. $\triangle EAB$ is isosceles
- e. $AB = \frac{1}{2}CD$

For problems 18 through 20, determine the area of the following composite figures. If the figure is shaded, find the area of the shaded portion of the figure.

Note: Figures NOT drawn to scale

18.

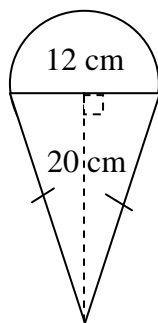

19.

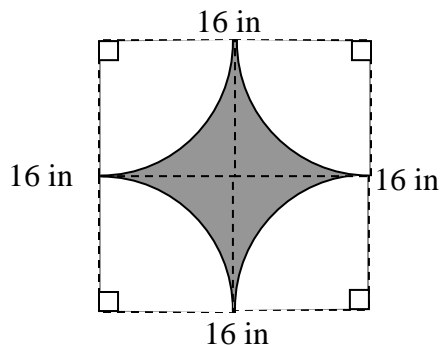

20. \overline{OR} and \overline{OS} are radii

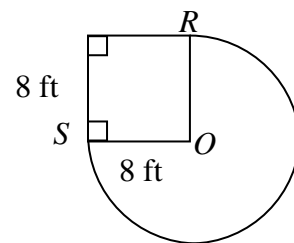

For problems 21 through 23, the lengths of three segments are given. State whether the triangle formed by the three segments is acute, right, or obtuse. Give reasons for your answers.

21. 6, 8, 10

22. 3, 8, 9

23. 9, 12, 14

For problems 24 and 25, determine the probability that a dart will hit the shaded area of the target.

24.

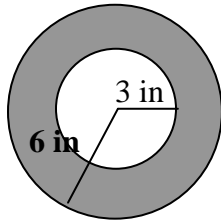

Note: Figure NOT drawn to scale

A $\frac{1}{4}$

B $\frac{1}{3}$

C $\frac{1}{2}$

D $\frac{3}{4}$

25.

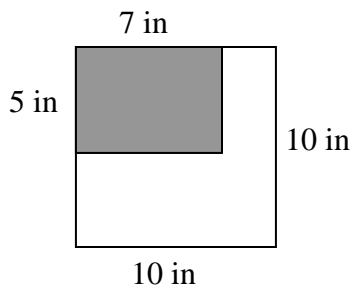

Note: Figure NOT drawn to scale

A $\frac{7}{20}$

B $\frac{3}{5}$

C $\frac{13}{20}$

D $\frac{7}{10}$

26. Complete the following coordinate proof.

Given: Right Isosceles triangle ABC with coordinates as shown.

Prove: *The median to the hypotenuse of an isosceles right triangle is perpendicular to the hypotenuse.*

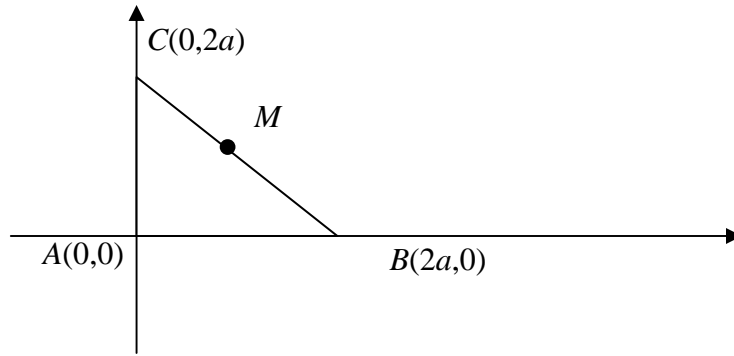

27. Complete the following coordinate proof:

Given: Quadrilateral $ROTS$ with vertices as labeled below.

Prove: *If the midpoints of the sides of a quadrilateral are connected, then the figure formed has opposite sides both parallel and congruent.*

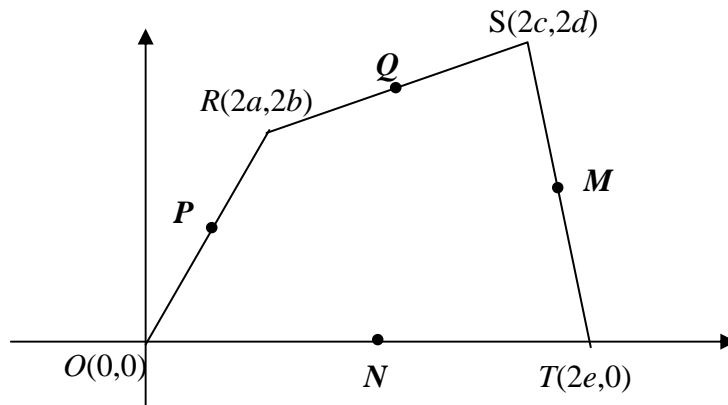

28. In each problem, the polygons are similar. Determine the value of x .

a.

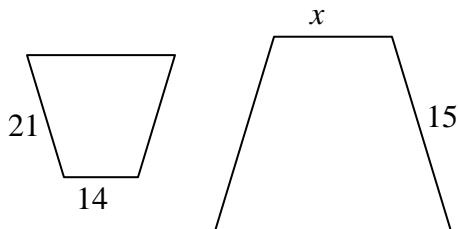

b.

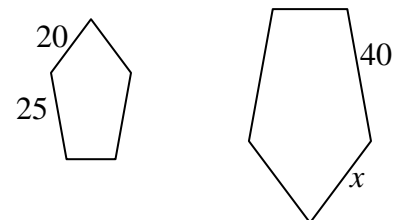

29. Which of the following statements are true?

- a. $\sqrt{7} \cdot \sqrt{5} = \sqrt{35}$
- b. $\frac{\sqrt{35}}{\sqrt{7}} = \sqrt{5}$
- c. $\sqrt{10} - \sqrt{3} = \sqrt{7}$
- d. $\sqrt{5} + \sqrt{6} = \sqrt{11}$
- e. $\sqrt{32} = \sqrt{16 \cdot 2} = 4\sqrt{2}$

For problems 30 through 34, complete the information for each solid..

Note: Figures NOT drawn to scale

30.

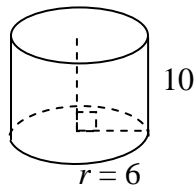

Surface Area: _____

Volume: _____

31.

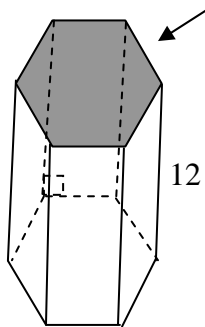

A regular hexagon with perimeter = 36
and area = $54\sqrt{3}$

Surface Area: _____

Volume: _____

32.

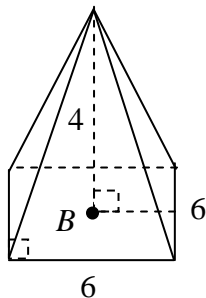

Point B is at the center of the square base.

Slant Height: _____

Surface Area: _____

Volume: _____

33.

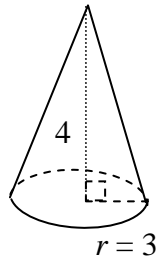

Slant Height: _____

Surface Area: _____

Volume: _____

34.

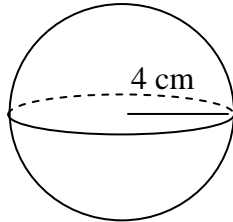

Surface Area: _____

Volume: _____

35. Find the volume of the following figures.

a.

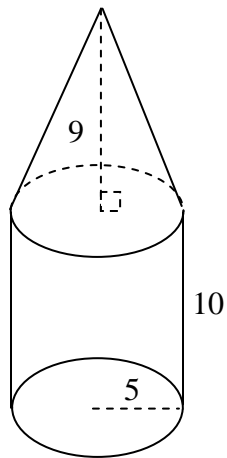

b.

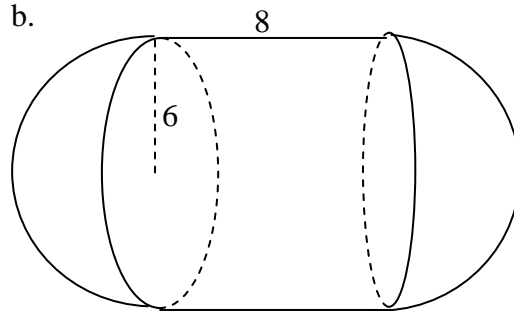

36. The ratio of the perimeter of two similar polygons is 5:7. What is the ratio of their areas?

37. The ratio of the volumes of two similar solids is 8:27. What is the ratio of their surface areas?

38. The ratio of the surface areas of two similar solids is 25:36. What is the ratio of their volumes?

- A** 5:6 **B** 25:36 **C** 125:216 **D** 625:1296

39. If the radius of a sphere is doubled, what will happen to the surface area of the sphere?

- A It will increase by a factor of 2.
- B It will increase by a factor of 4.
- C It will increase by a factor of 6.
- D It will increase by a factor of 8.

40. If each side of a cube is doubled, what will happen to the volume of the cube?

- A It will increase by a factor of 2.
- B It will increase by a factor of 4.
- C It will increase by a factor of 6.
- D It will increase by a factor of 8.

41. If the radius of a cylinder is doubled, and its height is tripled, what will happen to the volume of the cylinder?

- A It will increase by a factor of 3.
- B It will increase by a factor of 6.
- C It will increase by a factor of 12.
- D It will increase by a factor of 18.

42. Look at the right rectangular prism below.

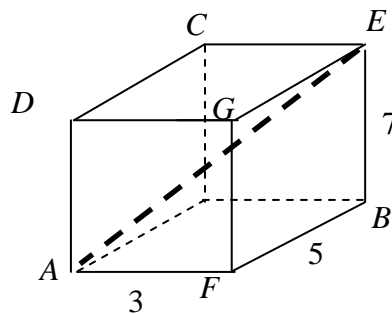

- a. What is the length of segment \overline{AE} ?
- b. What is the relationship between diagonal \overline{AE} and the prism?

43. A cube has a surface area of 24 in^2 . What is the volume of the cube?

44. Determine the distance between the following pairs of points.

- a. $(2,6)$ and $(5,9)$ b. $(-3,6)$ and $(2,1)$ c. $(-1,-1)$ and $(2,5)$

45. On the coordinate plane below, plot the points $A(-1,2)$, $B(0,1)$, and $C(2,3)$

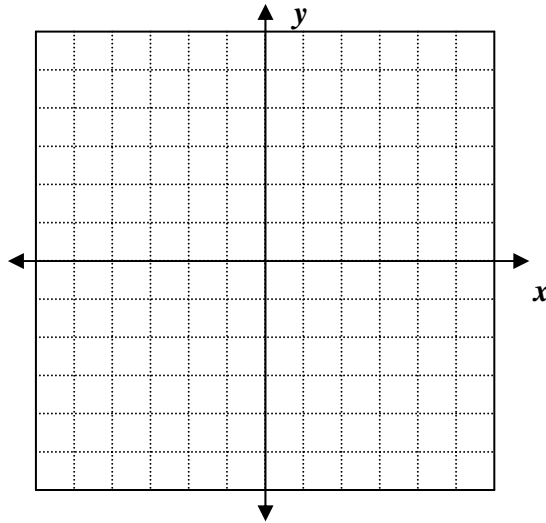

- Show that the triangle is a right triangle and determine its area.
- Using $(0,0)$ as the center of dilation and a scale factor of 2, draw the dilation image and state the coordinates of each vertex of the image.
- What is the ratio of the area of the dilation image to the pre-image? Use mathematics to justify your answer.

46. Regular pentagon $PRSTU$ below has a perimeter of 60.

It is dilated with a scale factor of $\frac{1}{3}$, with the center of dilation P to produce the shaded pentagon $PR'S'T'U'$.

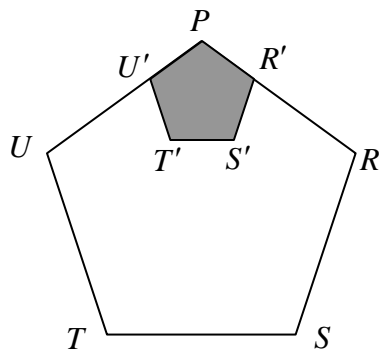

Note: Figure NOT drawn to scale

What is the length of $\overline{S'T'}$?

47. Look at triangles ABC and DCE below.

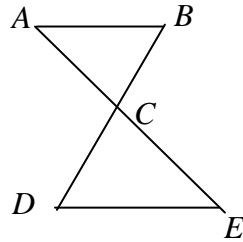

Note: Figure NOT drawn to scale

In parts (a), (b), and (c) below, determine whether the triangles are similar, based on the given information. Use mathematics to justify your answer.

- a. $\overline{AB} \parallel \overline{DE}$
- b. $BC = 14, AC = 16$
 $DC = 21, CE = 24$
- c. $AB = 10, BC = 20$
 $DE = 20, CD = 40$

48. What is the geometric mean of 6 and 12?

- A** $\sqrt{2}$ **B** $\sqrt{72} = 6\sqrt{2}$ **C** 18 **D** 72

49. If 6 is the geometric mean of 2 and x , what is the value of x ?

- A** 3 **B** 4 **C** 12 **D** 18

50. In the figure below, $m \parallel n \parallel p$.

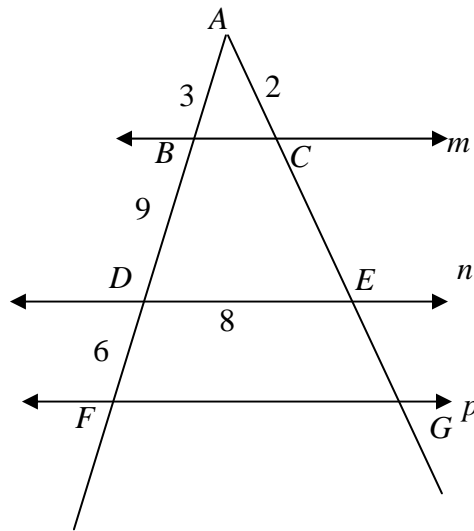

Note: Figure NOT drawn to scale

- What is the perimeter of triangle AFG ? Explain how you determined your answer. Use words, symbols, or both in your explanation.

51. In the figure below, the two cones are similar:

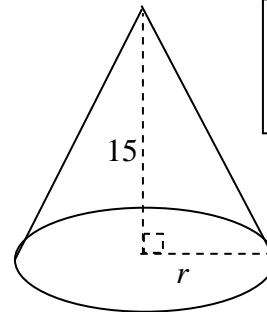
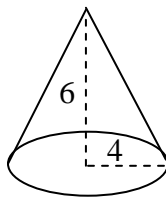

Note: Figures NOT drawn to scale

- What is the value of r ? Explain how you determined your answer. Use words, symbols, or both in your explanation.
- What is the ratio of the volumes of the cones? Use mathematics to justify your answer.

For problems 52 and 53, look at circle P below.

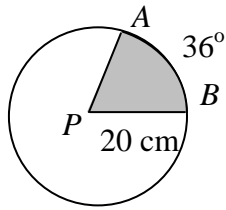

Note: Figure NOT drawn to scale

52. What is the length of \widehat{AB} ?
- A 4π B 8π C 80π D 160π
53. What is the area of the shaded sector?
- A 4π B 8π C 40π D 160π

54. In circle E below,
 \overline{AB} is tangent to the circle at A .
 $m\widehat{AD} = 90^\circ$ $m\widehat{DH} = 40^\circ$, $m\widehat{GH} = 30^\circ$

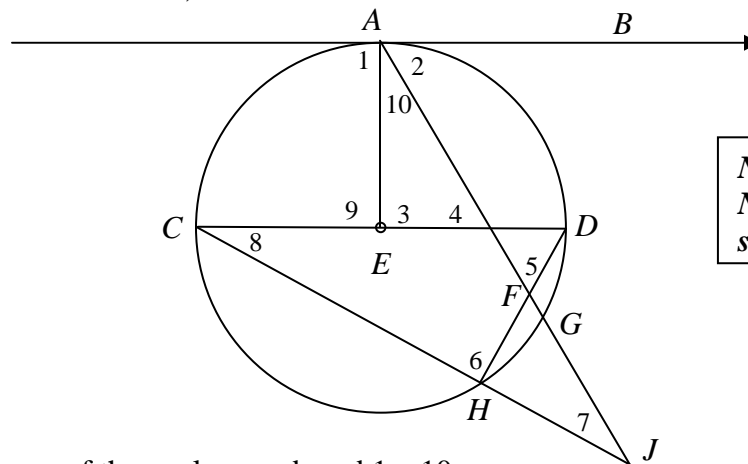

Note: Figure NOT drawn to scale

Find the measures of the angles numbered 1 – 10.

$m\angle 1 = \underline{\hspace{1cm}}$ $m\angle 2 = \underline{\hspace{1cm}}$ $m\angle 3 = \underline{\hspace{1cm}}$ $m\angle 4 = \underline{\hspace{1cm}}$ $m\angle 5 = \underline{\hspace{1cm}}$
 $m\angle 6 = \underline{\hspace{1cm}}$ $m\angle 7 = \underline{\hspace{1cm}}$ $m\angle 8 = \underline{\hspace{1cm}}$ $m\angle 9 = \underline{\hspace{1cm}}$ $m\angle 10 = \underline{\hspace{1cm}}$

55. Describe and sketch the locus of all points in a plane that are equidistant from each endpoint of \overline{AB} .

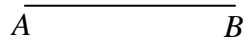

56. For a game, a spinner is in the shape of a circle with radius 10 cm. The spinner is divided into sectors. One sector intercepts an arc of 72 degrees. What is the area of that sector?

For problems 57 and 58, find the area of the shaded segments of the circles.

57.

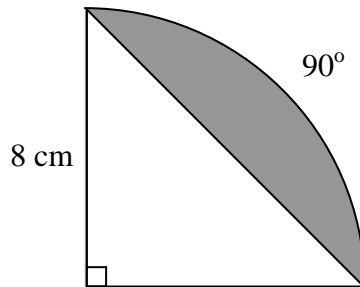

Note: Figure NOT drawn to scale

58.

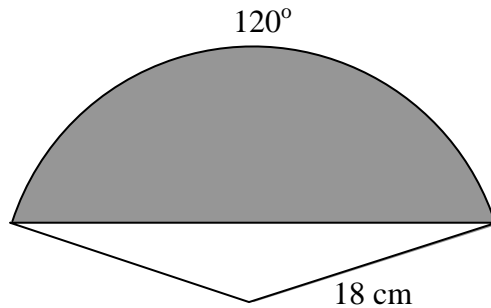

Note: Figure NOT drawn to scale

59. If two polygons are similar, what is known about their angles and sides?

60. Circle O has a diameter of 20.
 $UT = 16$, $SM = 24$
 $\overline{RS} \perp \overline{UT}$, $\overline{RS} \perp \overline{SM}$

Note: Figure NOT drawn to scale

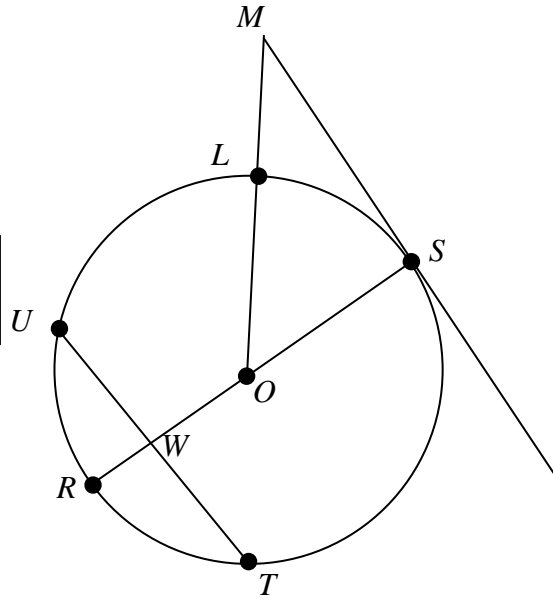

- a. What is the length of \overline{OW} ?
- b. What is the length of \overline{LM} ?

HONORS GEOMETRY ONLY

61. Describe the set of points *in space* that are equidistant from each endpoint of segment \overline{AB} .

For problems 62 through 64 below, $\triangle FGH$ is a right triangle, \overline{GK} an altitude.

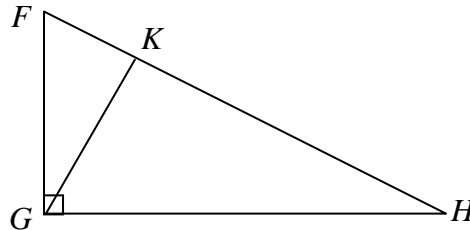

62. Which of the following are similar to triangle $\triangle FGH$?
- I Triangle $\triangle FKG$
 - II Triangle $\triangle GKH$
- A I only B II only C Both I and II D Neither I nor II
63. If $HK = 12$ and $FK = 3$, what is GK ?
64. Write three proportions using GK .
-

For Problems 65 and 66, use the unit circle below.

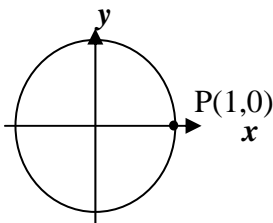

65. What angle of rotation will transform point P to an image of $P'(0,1)$?
66. What is $\sin 270^\circ$?

67. Kyle and Holly are 2000 feet apart and both are looking at a balloon. At one time, Holly sees the hot-air balloon with an angle of elevation of 42° , while at the same time, Kyle sees the balloon with an angle of elevation of 70° .

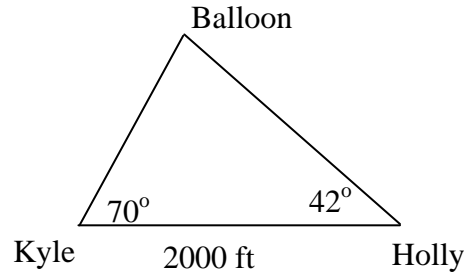

Note: Figure NOT drawn to scale

- How far are Holly and Kyle from the balloon? Explain how you determined your answer. Use words, symbols, or both in your answer.
- How high is the balloon? Explain how you determined your answer. Use words, symbols, or both in your answer.

- 68.

Farreed and Kim begin walking from the intersection of two roads. The angle between the roads is 40° , as shown in the figure below. Farreed walks 3 miles on one road, and Kim walks 4 miles on the other road.

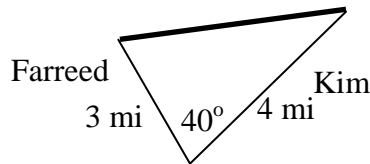

Note: Figure NOT drawn to scale

- What is the distance between Farreed and Kim? Explain how you determined your answer. Use words, symbols, or both in your answer.

69. Below are vectors \vec{u} and \vec{v} .



Sketch the resultant vector $\vec{u} + \vec{v}$ using both the head-to-tail and the parallelogram methods.

70. Jill can swim 6 miles per hour in still water. She tries to swim straight across a stream that has a current of 4 miles per hour. The dashed resultant vector is her path, shown in the drawing below.

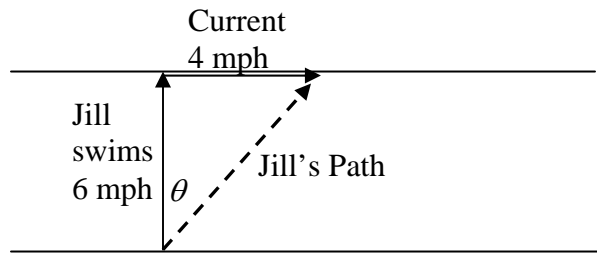

- a. At what speed is Jill traveling?
- b. At what angle, θ , is Jill swimming with respect to her intended path?